



***A cost and risk reducing test instrument for imaging sensor systems.....***

**ARTEMIS reduces the need for expensive real world trials by using off the shelf equipment to generate scenarios.**

**A test and verification tool that generates a synthetic environment and can provide the actual electrical returns that a sensor system would expect to receive.**

**What it does:** ARTEMIS provides a test-shell into which a system or any sub-group of its modules can be fitted for test and verification purposes. Test data do not need to be abstract engineering patterns (incrementing counts etc.) because they can be related to real-world scenarios, for example those agreed with a customer at the start of a project. Scenarios can be used safely to explore fringe conditions, extending those agreed with the customer. The ARTEMIS synthetic environment gives users full control over environmental conditions so performance in ideal conditions (e.g. no radar clutter) to worst-case conditions (e.g. serious clutter, multi-path, high receiver noise, bad weather, partially broken antenna) can be explored.

**How it's used:** ARTEMIS uses a selectable area on Google Earth with target information, platform performance information and the tracks the user wishes them to take (a scenario). Target, platform and track information are accepted in industry-standard CSV format, generated by modification of spreadsheet data (using Microsoft Excel for example) or by using the available visual toolset. Changing scenarios is as simple as selecting or (worst case)

### Benefits ...

- Risk Reduction
  - \* Improved communication
  - \* Easy 'what-ifs'
  - \* No bespoke test equipment
  - \* Pre-run a trial in-house
- Cost Reduction
  - \* Same test equipment for all stages of a project
  - \* Same test equipment on different projects
  - \* Buy or hire as needed
- Shorter Timescale
  - \* Reduce test and verification workload.
  - \* Common tests across all project phases from concept to acceptance.
  - \* Engineering learning time reduced due to reuse

## ARTEMIS - throughout the project life cycle.

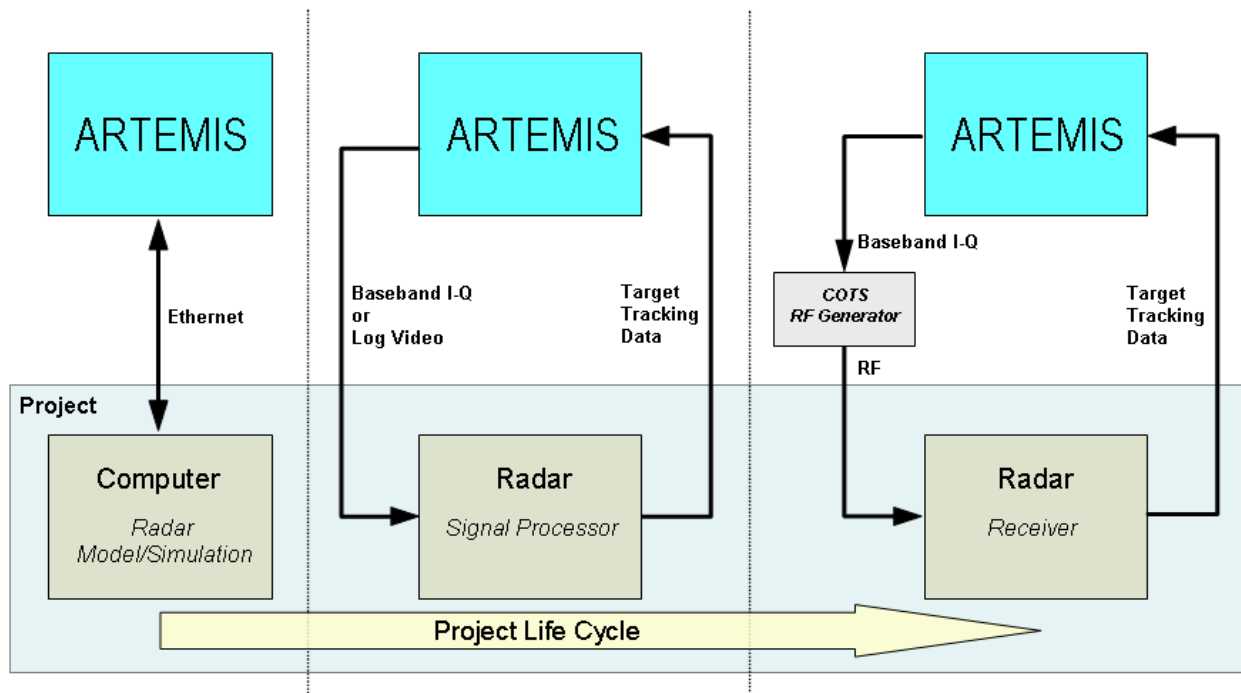

### Standard Features using Radar as an example (other sensor types are supported)

Multi Target Scenario Generator	<ul style="list-style-type: none"> <li>User definable scenarios</li> <li>Up to 10x simultaneous moving targets following user defined paths</li> <li>Real-time Scenario status displayed on Google Earth</li> </ul>
Radar Parameters	<ul style="list-style-type: none"> <li>Customer configurable radar parameters</li> <li>Frequency, Tx Power, Tx/Rx Gain, System Losses</li> </ul>
Range Amplitude Variation	<ul style="list-style-type: none"> <li>Automatic Gain Control (AGC) Emulation</li> <li>Customer definable AGC Range</li> <li>On/Off selectable AGC</li> <li>Support for Marine Radar</li> </ul>
Clutter	<ul style="list-style-type: none"> <li>Selectable amplitude</li> <li>Clutter model - Pseudo random</li> </ul>
Rx Noise	<ul style="list-style-type: none"> <li>Selectable amplitude</li> <li>Noise type - Pseudo random</li> </ul>
Chirp Waveforms	<ul style="list-style-type: none"> <li>User definable chirp waveforms</li> </ul>
Target Shapes	<ul style="list-style-type: none"> <li>User definable target signatures for identification</li> </ul>
Doppler	<ul style="list-style-type: none"> <li>Doppler shift</li> <li>High definition range support</li> </ul>
Output	<ul style="list-style-type: none"> <li>Analogue, Log Video (1V max)</li> </ul>

### Optional Features

Clutter	<ul style="list-style-type: none"> <li>Addition of Multiple clutter models</li> </ul>
Beam-shapes	<ul style="list-style-type: none"> <li>3-D Beam Patterns, Horizontal &amp; vertical profile</li> </ul>
Doppler	<ul style="list-style-type: none"> <li>Addition of Micro Doppler capability</li> </ul>
Output	<ul style="list-style-type: none"> <li>Analog baseband I-Q</li> <li>Ability to drive COTS RF signal generators</li> </ul>
Customisation	<ul style="list-style-type: none"> <li>Additional interfaces such as 1553 and ARINC 429</li> <li>Special interfaces and additional features – RTDC will work with you to provide support for your specific requirements.</li> </ul>

There are other data sheets in this series, providing more detailed information – please ask.